

ZB SERIE – CURVED RADIAL BLADES

Common operating range

- FLOW RATE (m³/h)**



Low		Medium		High	
450	2000	4000	15000	X	X

- TOTAL PRESSURE (Pa)**



Low		Medium		High	
X	X	2000	4000	5000	10000

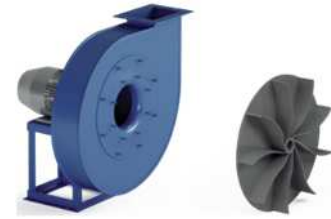

Recommended

To avoid

- APPLICATION**

Domain	Industry	General	Chemical	Process	Other
	<i>Pneumatic</i>	<i>Medium flow High pressure</i>	X	<i>Medium flow High pressure</i>	<i>Consult us</i>
Dust level	Clean	Medium	High		
	<i>Air, steam</i>	<i>Air, steam</i>	X		
Solid matter	Low	Medium	High		
	<i>Saw dust, wood shavings</i>	<i>Saw dust, wood shavings</i>	X		
Filamentary material	Low	Medium	High		
	<i>Fiber, thread, textiles</i>	<i>Fiber, thread, textiles</i>	X		

Total pressure (mmH₂O or x9.79Pa)

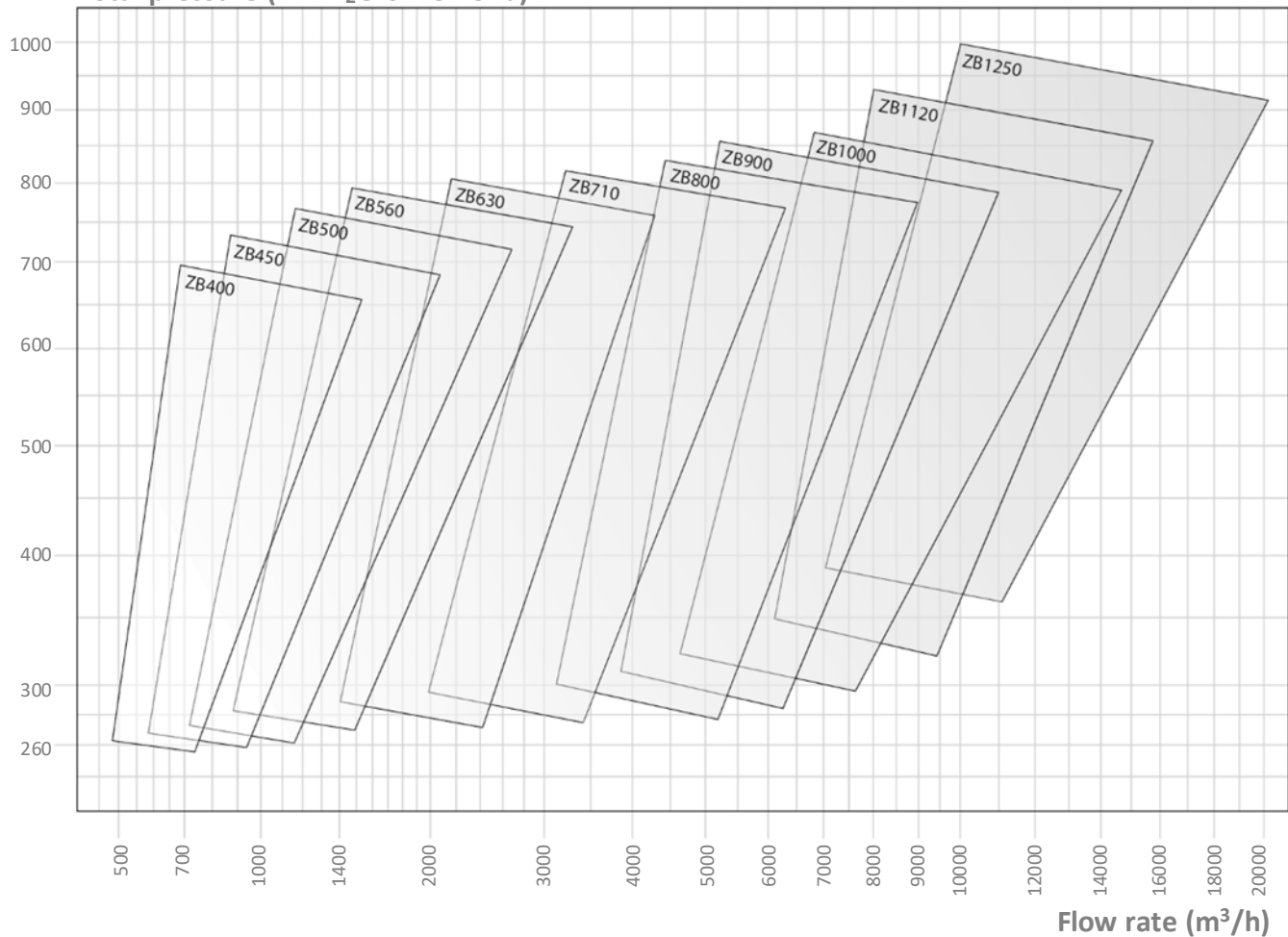

ZB DIMENSIONS

General dimensions

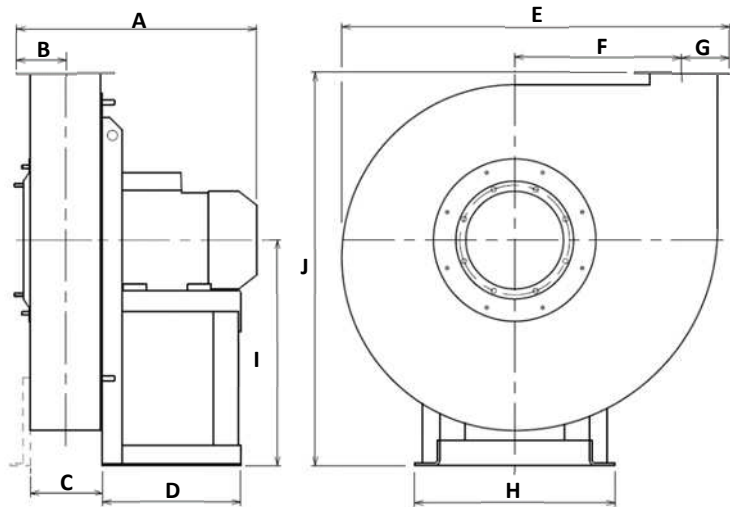
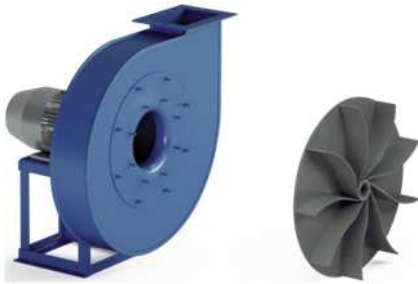

ZB...	No. of poles	HA* mm	Inst. P kW	Mot. V rpm	Weight ** kg	A*** mm	B mm	C mm	D mm	E mm	F mm	G mm	H mm	I mm	J mm
ZB800	/4R	132	7.50	1470	250	648	155	242	336	1237	481	201	372	710	1240
ZB800	/4	160	11.00	1480	276	753	155	242	436	1237	481	201	440	710	1240
ZB900	/4R	160	11.00	1480	393	780	169	268	436	1390	542	221	440	800	1400
ZB900	/4	160	15.00	1480	406	780	169	268	436	1390	542	221	440	800	1400
ZB1000	/4R	180	18.50	1480	562	893	184	300	460	1540	607	242	488	900	1570
ZB1000	/4	180	22.00	1480	577	944	184	300	460	1540	607	242	488	900	1570
ZB400	/2	90	2.20	2900	60	437	94	126	251	640	238	118	260	375	655
ZB450	/2	100	3.00	2920	70	482	101	140	285	705	265	128	324	400	700
ZB450	/2	112	4.00	2920	78	503	101	140	285	705	265	128	324	400	700
ZB500	/2	132	5.50	2920	106	560	110	156	345	780	297	139	372	450	785
ZB500	/2	132	7.50	2960	107	560	110	156	345	780	297	139	372	450	785
ZB560	/2	132	7.50	2960	130	579	119	176	345	880	337	151	372	500	875
ZB560	/2	160	11.00	2960	164	684	119	176	446	880	337	151	440	500	875
ZB630	/2	160	15.00	2960	182	703	128	196	446	985	381	164	440	560	985
ZB630	/2	160	18.50	2960	194	703	128	196	446	985	381	164	440	560	985
ZB710	/2R	180	22.00	2960	311	809	143	216	460	1035	426	184	488	630	1103
ZB710	/2	200	30.00	2960	445	917	143	216	500	1035	426	184	568	630	1103
ZB710	/2	200	37.00	2960	447	917	143	216	500	1035	426	184	568	630	1103
ZB800	/2R	200	37.00	2960	520	942	155	242	500	1237	481	201	568	710	1240
ZB800	/2	225	45.00	2960	603	984	155	242	540	1237	481	201	616	710	1240
ZB800	/2	250	55.00	2970	661	1092	155	242	600	1237	481	201	690	710	1240

Notes:

(*) HA is the motor frame size.

(**) Due to multiple sourcing of motors, there may be weight differences (motor in cast iron or aluminium, single-speed or dual-speed, etc.)

(***) A is variable depending on the motorization.

For diameters greater than 1000mm, contact us.